



AS-80-8/15 SERVO AMPLIFIER FOR BRUSH SERVOMOTORS



USER GUIDE April 2007



Important Notice

This document is subject to the following conditions and restrictions:

- This document contains proprietary information belonging to Callan Technology Ltd.
- This information is provided for the purpose of assisting users of the servo drive in its installation.
- The text and graphics in this document are for the purpose of illustration and reference only.
- The information in this document is subject to change without notice.

Revision History:
Version 1.00: 17th April 2007



Table of Contents

1. Introduction -----	4
1.1 Description-----	4
1.2 Technical Specifications -----	5
2. Safety Information -----	6
2.1 Electrical Cautions-----	6
3. Installation -----	7
3.1 Matching the AS-80-8/15 to the Motor-----	7
3.1.1 Voltage Measurement for the RMS -----	8
3.2 Mounting Dimensions-----	9
3.3 Connector Information -----	Error! Bookmark not defined.
3.3.1 J1 – Control I/O Connection -----	10
3.3.2 J2 - Servomotor Connection-----	11
3.3.3 J5 - Encoder Inputs -----	11
3.4 Wiring Diagram-----	12
3.4.1 Connection Diagram-----	12
3.4.2 Encoder-to-Tach Function-----	Error! Bookmark not defined.
3.5 Potentiometers -Adjustments -----	14
4. Operational Modes -----	15
4.1 Torque Mode-----	15
4.1.1 Torque Mode – Factory Potentiometer Settings-----	15
4.1.2 Torque Mode - Setup-----	16
4.2 Velocity Mode-----	17
4.2.1 Velocity Mode – Factory Potentiometer Setting -----	17
4.2.2 Velocity Mode- Setup-----	18
4.3 Encoder to Tach (Optional)-----	19
5. Troubleshooting -----	20
5.1 Diagnostic LEDs -----	20
5.1.1 Green LED -----	20
5.1.2 Red LEDs:-----	20
5.1.2.1 BUS OVER VOLTAGE -----	20
5.1.2.2 RMS/OVER TEMP -----	20
5.1.2.3 SURGE/GROUND FAULT-----	20
5.2 Other Conditions -----	21
5.3 Test Points-----	21
5.4 Contact Information -----	22



1. Introduction

This information manual provides the product specifications, wiring diagram, operational modes (torque and velocity) and troubleshooting procedures for the brush AS-80-8/15.

1.1 Description

The AS-80-8/15 supplies 8 amps continuous current and 15 amps peak current at 80 VDC for a total of 640 watts of continuous power. The high voltage bus supply requires an isolation step-down transformer.

The AS-80-8/15 is a current source type PWM amplifier.

The AS-80-8/15 is a power duplicator of the command signal. A battery, a motion controller, or a signal generator can be the source of the command signal input.

Please read this manual thoroughly to the end as it contains important system information and warnings.



1.2 Technical Specifications

Performance Characteristics	
Peak Power	1.1 kW
Peak Output Voltage	± 75 vdc (shut off @ 95 vdc)
Peak Output Current	± 15 amps (1 sec.)
Max. Continuous Current	± 8 amps (50 °C)
	± 10 amps (25 °C)
Electrical Characteristics	
Input Signal Voltage	± 10 vdc (typ.)
	± 35 vdc (max.)
System Gain	0 to 5100 amps/volt
Input Impedance	40 k Ohms
Typical Input Drift	10 µV/°C
Bandwidth	2 kHz with 1.2 mH Inductance
Dead Band	Zero
Input Power Requirements	
Input Voltage	20 - 80 vdc
Adjustments	
Peak Current Limit	0 to 15 amps
RMS Current Limit	0 to 10 amps.
Signal Command Input	Scaling
Balance	Zero velocity offset
Compensation	System response
Tachometer	Scaling
Diagnostics	
	LED indication
Red	LED 1 - BUS OVER VOLTAGE
Red	LED 2 - EXCESSIVE RMS CURRENT/ OVER TEMP
Red	LED 3 - SURGE/GROUND FAULT
Green	LED 4 - RUN GREEN – AMPLIFIER OPERATIONAL
Physical Characteristics	
Module Dimensions	(L x W x H) 137mm x 25mm x 81mm
Weight	318 grams
Ambient Temperature – Operating	0 °C to 50 °C
Shutdown Temperature	80 °C at heat sink
Relative Humidity	5 - 95% non-condensing

Table 1: Technical Specifications for AS-80-8/15 815



2. Safety Information

2.1 Electrical Cautions

- Ensure that the negative terminal of the bus capacitor is grounded to the earth ground.
- Improper grounding may cause erratic operation or a safety hazard due to common mode voltages.
- An isolation step-down transformer must be used for the power supply of this unit. Do not ground either leg of the transformer secondary.
- Make sure that all voltages and tests are made with battery powered or electrically isolated instruments.



3. Installation

3.1 Matching the AS-80-8/15 to the Motor

The factory preset potentiometer settings may need to be adjusted to match the continuous current rating of your motor. To accomplish this, find the continuous current rating of the motor to be used and adjust the RMS, PEAK CURR LIMIT and SIGNAL pot per Table 2 below. If the continuous current rating lands in between the values shown in the table, you may set to the lower value or use linear interpolation for each pot value. The cover of the AS-80-8/15 must be removed to get to TP8. Refer to Table 3 for Voltage Measurement for the RMS.

Continuous Current Rating of Motor (Amps)	RMS Pot Setting TP8 (Amps)	PEAK CURRENT LIMIT Pot Setting TP5 K Ohms (Amps)	SIGNAL Pot Setting TP2 K Ohms
2	4.00 K (2 Amps)	0.68 K (6 Amps)	1.4 K
3	4.90 K (3 Amps)	1.15 K (9 Amps)	2.1 K
5	5.75 K (5 Amps)	2.48 K (15 Amps)	3.5 K
8	4.10 K (8 Amps)	2.48 K (15 Amps)	3.5 K
10	1.34 K (10Amps)	2.48 K (15 Amps)	3.5 K

Table 2: Motor Specs

Note: All Measurements are with respect to TP1 (Common) with J1 removed.



3.1.1 Voltage Measurement for the RMS

AMPS	VOLTS ON TP-8
1.00	1.00
1.50	1.30
2.00	1.40
2.50	1.90
3.00	2.00
3.50	2.40
4.00	2.55
4.50	3.00
5.00	3.10
5.50	3.30
6.00	3.60
7.00	3.90
8.00	4.20
9.00	4.60
10.00	5.00

Table 3: Voltage Measurement for the RMS



3.2 Mounting Dimensions

Note: Units in inch

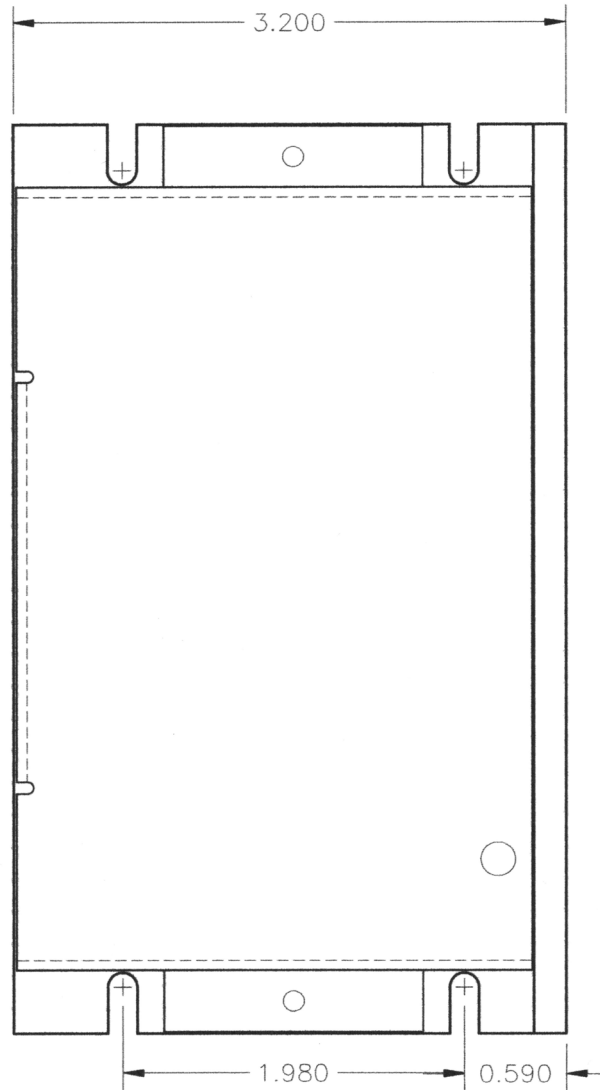
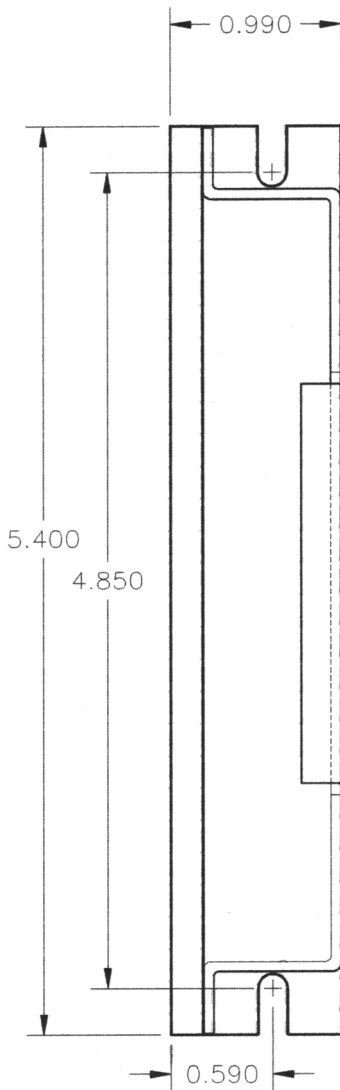
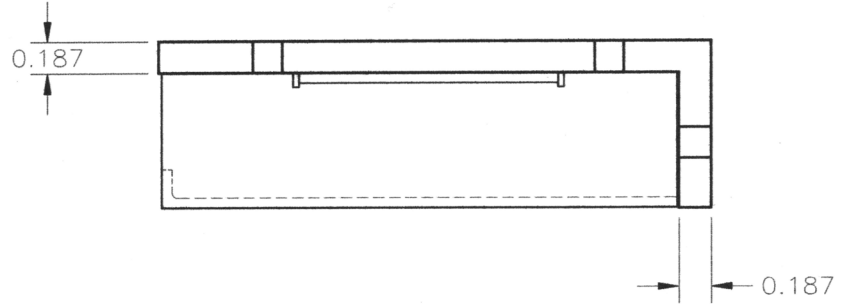



3.3 Connector Information

3.3.1 J1 – Control I/O Connection

J1	Label	Description
1	+ 10V, 5mA OUT	Auxiliary voltage available for customer use.
2	COMMON	Connected to other commons and connected to the metalwork of the heat sink.
3	- 10V, 5mA OUT	Auxiliary voltage available for customer use.
4	COMMAND +	Differential input.
5	COMMAND -	Differential input. This pin can also be used as a single ended input. Use J1, pin 2 as common.
6	TACH IN	Single ended input that has additional tach filtering and conditioning.
7	COMMON	See pin 2 above.
8	CURR MONITOR OUT	Current monitor output. +/- 10 Vdc out equals approx. +/- 15 amps.
9	CURR REFERENCE	Current command signal to the internal current loop.
10	NC	No connection
11	INHIBIT/RESET	Internally pulled to + 5Vdc. With JL2 jumper installed, Pull to common to inhibit and reset amplifier. With JL2 jumper removed, release from common to inhibit and reset amplifier.
12	LIMIT SWITCH +	Inhibits motor over travel for the + direction (J2-1 = +voltage). With JL1 jumper installed, pull to common to inhibit. With JL1 jumper removed, release from common to inhibit.
13	LIMIT SWITCH -	Inhibits motor over travel for the – direction (J2-1 = -voltage). With JL1 jumper installed, pull to common to inhibit. With JL1 jumper removed, release from common to inhibit.
14	FAULT OUTPUT	Uncommitted collector output that is low (On) during normal operation and high (off) if a fault occurs or drive is disabled. Note: Internally pull up to 510 mA max.
15,16	NC	No connection.



3.3.2 J2 - Servomotor Connection

J2	Label	Description
1	MOTOR +	Output power to motor
2	MOTOR -	Output power to motor
3	- DC BUS IN	- Bus power Input, power return
4	- DC BUS IN	- Bus power Input, power return
5	+ DC BUS IN	+ Bus power input, 20 to 80 Vdc

3.3.3 J5 - Encoder Inputs

5 Volt Logic (Type .1 inch spacing)

The J5 Pins are used as encoder inputs when the Encoder to Tach feature is used. The encoder's outputs may be single ended or line driver.

Refer to Section 4.3 for Encoder to Tach option.



3.4 Wiring Diagram

3.4.1 Connection Diagram



3.4.2 Encoder-to-Tach Function

- J1 CONNECTOR**
- PIN 1 +10V, 5mA OUT
 - PIN 2 COMMON
 - PIN 3 -10V, 5mA OUT
 - PIN 4 COMMAND+
 - PIN 5 COMMAND-
 - PIN 6 TACH IN
 - PIN 7 COMMON
 - PIN 8 CURR MONITOR OUT
 - PIN 9 CURR REFERENCE
 - PIN 10 NC
 - PIN 11 INHIBIT/RESET
 - PIN 12 LIMIT SWITCH+
 - PIN 13 LIMIT SWITCH-
 - PIN 14 FAULT OUTPUT
 - PIN 15 NC
 - PIN 16 NC

- J2 CONNECTOR**
- PIN 1 MOTOR +
 - PIN 2 MOTOR -
 - PIN 3 - DC BUS IN
 - PIN 4 - DC BUS IN
 - PIN 5 + DC BUS IN

- J5 CONNECTOR**
- PIN 1 ENCODER A
 - PIN 2 ENCODER B
 - PIN 3 COMMON

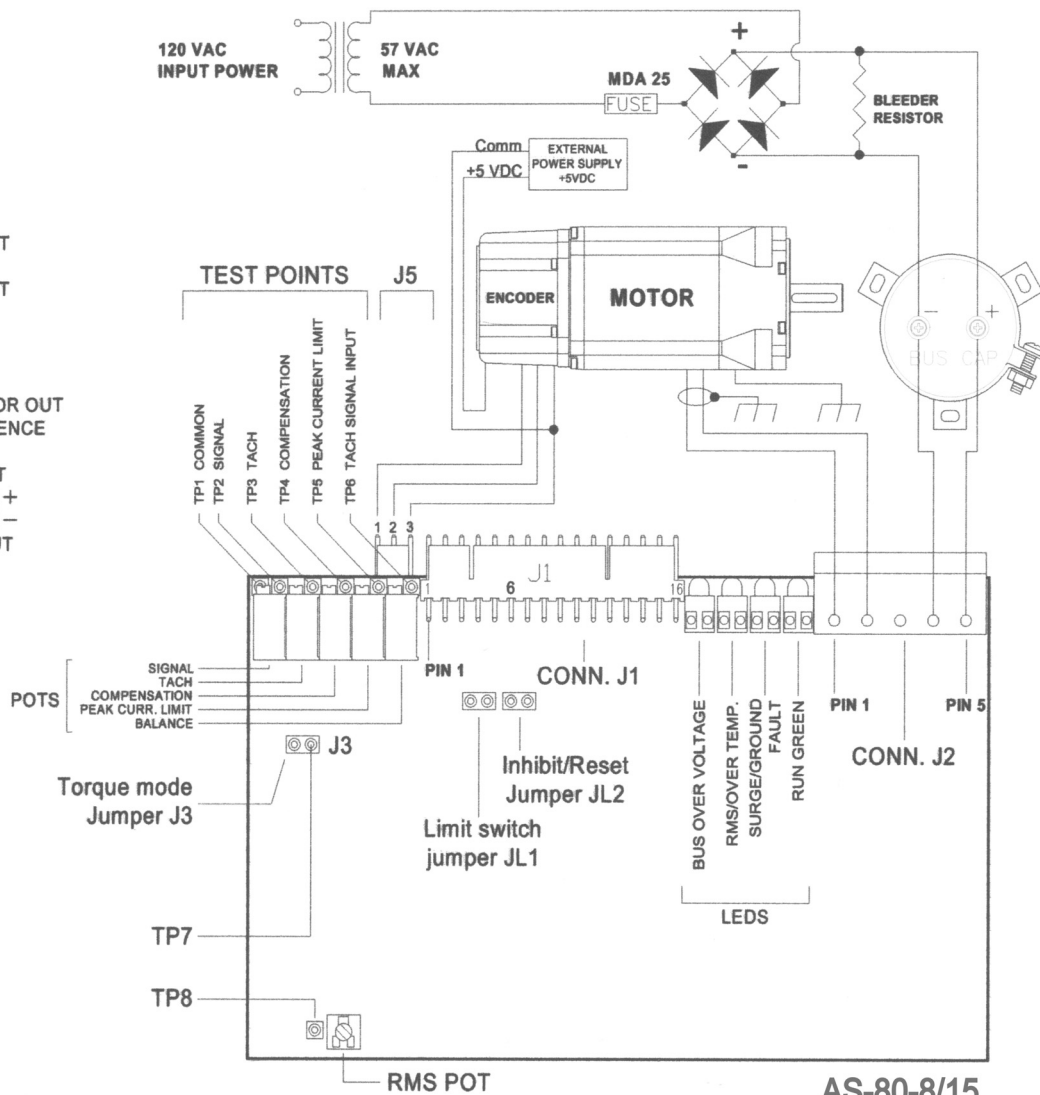

NOTE: Heat sink must be tied to ground

AS-80-8/15



3.5 Potentiometers -Adjustments

The following is a description of the function of each pot. The pot settings can be measured at test points TP1 thru TP8.

Potentiometer	Description
SIGNAL	The signal potentiometer is used for scaling the command signal. Turning the potentiometer CW increases the amount of command signal to the front end of the amplifier.
TACH	The tachometer potentiometer is used for scaling the various tachometer voltage gradients. This input has to be used because of special signal conditioning. Turning the pot CW increases the amount of tach-feedback into the amplifier.
COMPENSATION	The Compensation potentiometer is used to increase or decrease the response (bandwidth) of the amplifier. Turning the potentiometer CW increases the response of the amplifier.
PEAK CURR LIMIT	The peak current limit potentiometer is used to increase or decrease the peak output current of the amplifier. Turning the potentiometer CW increases the output current of the amplifier from zero amps to maximum peak amps.
BALANCE	The balance potentiometer is used to stop motor rotation when no input signal exists. The function of this pot is such that for zero input volts the output current should be at zero amps.
RMS	The RMS potentiometer is for changing the level of the RMS current. The amplifier is capable of providing maximum RMS current when fully CW. The minimum current is approximately 0 amps when fully CCW.



4. Operational Modes

The AS-80-8/15 can operate in a Torque or Velocity mode.

In the Torque mode, the AS-80-8/15 only closes the torque loop. The velocity loop is closed in the motion controller.

In the Velocity mode, the AS-80-8/15 itself closes both the torque and velocity loop. Unless otherwise specified, the AS-80-8/15 is preset from the factory in the torque mode.

4.1 Torque Mode

4.1.1 Torque Mode – Factory Potentiometer Settings

The AS-80-8/15 is shipped in the torque mode by installing the torque mode jumper at J3 and presetting the potentiometers for the torque mode. The factory potentiometer settings for the torque mode are as follows: (See ADJUSTMENTS section for a more complete description of the potentiometer functions)

Potentiometer Description	Potentiometer Setting	Potentiometer Test Point
N/A	N/A	TP1 – COMMON
SIGNAL	3.5 K Ohms	TP2 – SIGNAL
TACH	Full CCW (0 Ohms)	TP3 – TACH
COMPENSATION	Full CW (0 Ohms)	TP4 – COMPENSATION
PEAK CURR LIMIT	2.4 K Ohms (15 Amps)	TP5 – PEAK CURR LIMIT
BALANCE	No Preset	None
RMS	1.34 K Ohms (10 Amps)	TP8 – RMS

Table 4: Torque Mode POT settings

Note: All Measurements are with respect to TP1 (Common) with J1 removed.



4.1.2 Torque Mode - Setup

The factory preset potentiometer settings are adjusted for the torque mode operation.

To set up and run the AS-80-8/15 in the torque mode, perform the following:

1. Turn power off.
2. Remove J1.
3. Check all wiring connections. Verify that J3 jumper is in place.
4. Set the RMS, PEAK CURRENT LIMIT and SIGNAL pots to match the motor as indicated in Table 2. For preliminary testing under no load, use the factory preset pot settings.
5. Check that the TACHOMETER pot is full counterclockwise (CCW).
6. Check that the COMPENSATION pot is full clockwise (CW).
7. Replace J1.
8. Inhibit the AS-80-8/15 by pulling pin 11 of J1 to common.
9. Turn power on.
10. Insure that the voltage at COMMAND + and COMMAND – is zero.
11. Enable the AS-80-8/15 by removing the inhibit of step 8.
12. The green LED should be the only LED on. No other LEDs should be on at this point. If any other situation exists, check the TROUBLESHOOTING section of this manual.
13. Adjust the BALANCE pot to give zero volts at CURRENT MONITOR OUT, J1 pin8.
14. Apply a voltage (0 to +/- 10 Vdc) at COMMAND + and COMMAND -. The motor shaft should turn CW when COMMAND + is positive and should turn CCW when COMMAND + is negative. At low COMMAND voltage, holding the shaft can stall the motor. At higher COMMAND voltage, the torque is much greater and it should be difficult to stall the motor.



4.2 Velocity Mode

4.2.1 Velocity Mode – Factory Potentiometer Setting

To set the AS-80-8/15 in the Velocity Mode, remove the cover to expose TP8 and the Torque Mode Jumper at J3. Remove the Torque Mode Jumper at J3 that is located right behind the Tach pot. The pot settings must be adjusted for Velocity mode as per Table 5. The Velocity mode requires a tachometer feedback signal from the motor or motion control system.

To match the motor to the AS-80-8/15, set the RMS and SIGNAL pots per Table 2, but set the PEAK CURR LIMIT pot to full CCW for the initial setup of the system. Set the remaining pots per Table 5.

Potentiometer Description	Potentiometer Setting	Potentiometer Test Point
N/A	N/A	TP1 – COMMON
SIGNAL	See Table 2	TP2 – SIGNAL
TACH	7.0 k Ohms	TP3 – TACH
COMPENSATION	Full CCW	TP4 – COMPENSATION
PEAK CURR LIMIT	Full CCW	TP5 – PEAK CURR LIMIT
BALANCE	No Preset	None
RMS	See Table 2	TP8 – RMS

Table 5: Velocity Mode POT settings

Note: All Measurements are with respect to TP1 (Common) with J1 removed.



4.2.2 Velocity Mode- Setup

To set up and run the AS-80-8/15 in the Velocity mode, perform the following:

1. Turn power off.
2. Remove J1.
3. Check all wiring connections. Verify that J3 jumper is removed.
4. Check that the pots are set per Table 5
5. Inhibit the AS-80-8/15 by pulling pin 11 of J1 to common.
6. Replace J1.
7. Turn power on.
8. Insure that the voltage at COMMAND + and COMMAND – is zero.
9. Enable the AS-80-8/15 by removing the inhibit of step 5.
10. The green LED should be the only LED lit. No other LEDs should be lit At this point. If any other situation exists, check the TROUBLESHOOTING section of this manual.
11. Slowly turn the PEAK CURR LIMIT pot CW. If the motor runs away, turn the power off, reverse the velocity feedback leads and repeat above. If the motor does not run away, set the PEAK CURR LIMIT pot to the value given in Table 2.
12. Turn the COMPENSATION pot CW until the motor starts buzzing. Now turn the pot CCW until the motor stops buzzing and then turn another 1 ½ turns CCW.
13. The motor shaft should not be rotating at this point. If it is slowly rotating, adjust the BALANCE pot until rotation is stopped.

With zero voltage at COMMAND + and COMMAND –, the motor shaft should be stiff and difficult to turn. A low voltage at COMMAND + will cause the motor to turn at a slow speed with high torque and the motor should be difficult to stall. The motor speed should be proportional to the COMMAND voltage.



4.3 Encoder to Tach (Optional)

The Encoder to Tach (Frequency to Voltage Converter) is used to create a tachometer signal from a square wave encoder.

The maximum pulse rate of the Encoder to Tach is set by its output non-linearity. The output scaling of 1.7 V/1000RPM has been verified to be linear with a 2500 Line encoder with Line Driver outputs up to 3000 RPM.

For Encoder Inputs refer to Section 3.3.3.



5. Troubleshooting

5.1 Diagnostic LEDs

There are four diagnostic LEDs:

- 1) RUN GREEN
- 2) BUS OVER VOLTAGE
- 3) RMS/ OVER TEMP
- 4) SURGE/ GROUND FAULT

5.1.1 Green LED

RUN GREEN - Indicates the amplifier is working properly. When the green LED goes OFF and there is no red LEDs ON, the following may have occurred:

1. Loss of power to the amplifier.
2. Bus Voltage less than 18 VDC.
3. Amplifier has been inhibited by J1, Pin 11.

5.1.2 Red LEDs:

Note: When a red LED is ON, the amplifier has been inhibited and remains inhibited until reset. To reset, toggle J1 pin 11 momentarily to Common.

5.1.2.1 BUS OVER VOLTAGE

Indicates that the bus voltage has exceeded 95 VDC. This condition may be caused by rapid deceleration or back driving of the motor. A shunt regulator is required to dissipate the motor energy. If a shunt regulator is present in the system check its fuses.

5.1.2.2 RMS/OVER TEMP

- **Excess RMS** - The amplifier delivered current beyond its continuous capability. This condition can exist if a machine is asked to perform a task greater than its design capabilities. This would include a motor that is mechanically stalled or binding or a motor with shorted stator (armature) wires.
- **Over temperature** - The heat sink has exceeded 80 °C. An over temperature condition may exist for the following reasons:
 1. Insufficient airflow across the heat sink.
 2. Ambient cabinet temperature too high.

5.1.2.3 SURGE/GROUND FAULT

- **Surge** - Indicates an excessive amount of current through the power transistors in the output power bridge. This condition may be due to a damaged output power device or shorted output leads to the motor.
- **Ground fault** - One of the output wires to the motor is shorted to ground. This condition may be due to faulty or pinched wiring or the motor is arcing to the case ground.



5.2 Other Conditions

Problem	Possible Solution
MOTOR OR MACHINE RUNS AWAY	<ol style="list-style-type: none"> 1. Check the tachometer voltage to the amplifier by testing TP3 with respect to TP1. Then look at TP6 with respect to TP1 with a voltmeter. 2. Ensure the tachometer signal is phased correctly. 3. Check to see if the position loop phasing (CNC command) is correct relative to the position encoder feedback device.

5.3 Test Points

Test Point Pin	Observed Signal
TP1	COMMON
TP2	SIGNAL input POT wiper
TP3	TACH input wiper
TP4	COMPENSATION POT wiper
TP5	PEAK CURR LIMIT POT wiper
TP6	TACH IN signal directly connected to J1, pin 3 thru a 10K resistor
TP7	Front-end op-amp output (J3, pin 2)
TP8	RMS current setting pot wiper



5.4 Contact Information

Contact the service department at Callan Technology Ltd.:

Callan Technology Ltd.
Bay K 12a/12b
Shannon Industrial Estate
Ennis
Co. Clare
Ireland

Tel: +353 (61) 47 57 82

Fax: +353 (61) 47 57 83